

Automatic Impedance Matching System, WR340

GERLING

Model GA1022

The GA1022 Automatic Impedance Matching System integrates a high power vector impedance analyzer and motorized 3-stub waveguide tuner in a single compact waveguide component for use in industrial microwave heating applications. Designed for CW, high-ripple ("rectified") and pulsed microwave power operation modes, the GA1022 measures both magnitude and phase of reflection coefficient as well as incident, reflected and absorbed power and frequency, then utilizes that information to automatically control the tuner to rapidly optimize the impedance match. The GA1022 is available with Windows® based software for effective monitoring and recording of impedance measurements, and it can operate either autonomously without an external controller or by remote control from a personal computer via RS232 or optional CAN or DeviceNet interface.

The optional control, visualization and data logging software significantly expands the system capabilities. Basic features include:

- ◆ Microsoft Windows® environment
- ◆ Accurate measurement of complex reflection coefficient and its displaying in various formats, including
 - Magnitude and Phase angle
 - Return Loss and VSWR
 - Polar displays of Smith (Z and Y) and Rieke-type Charts
- ◆ Measurement of incident, reflected, and absorbed power and display in various formats, including Watts, decibels, percentage of incident power
- ◆ Numerical readout of signal frequency, load reflection coefficient and power in various formats
- ◆ Arbitrary shifting of the measurement reference plane
- ◆ Saving measured data as tables (text files) or pictures (BMP, GIF, JPG)
- ◆ Periodic data logging of all or some of the measured quantities
- ◆ Multiple windows enabling simultaneous observation of various quantities in different formats
- ◆ Wide selection of appearances of displayed curves
- ◆ Storing and retrieving of complete system settings matched to particular tasks

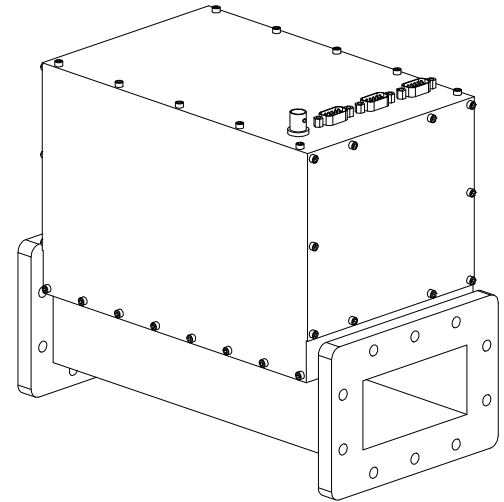

Electrical Specifications:

Frequency	2425-2475 MHz
Maximum Power	30 kW (continuous and peak)
Minimum Power	1 W
Dynamic Range	20 dB maximum
Measurement Error	Reflection coefficient: .05 max. Incident power: 5% max.
Waveform	Standard: CW, rectified Optional: pulsed
Max CW Ripple	15% of peak value
Rectified mode	400 pps maximum
Pulse mode	100 us minimum pulse width 100 ms maximum pulse period
Input Voltage	24 V \pm 10% DC, 625 mA
Control Interface	RS-232
Tuning Accuracy	As low as 1% reflection (depends on characteristics of microwave generator and load)
Time to optimal match	0.5 to 6 seconds (depends on initial load mismatch)

Mechanical Specifications:

Waveguide	WR340 (RG113/U)
Flange	CPR-F (UG554/U)
Electrical Connections	9-pin male D-sub
Construction	Aluminum waveguide
Weight	13 lbs (6 kgm)
Overall Dimensions	(see outline drawing)
Operating Temperature	40 °F (5 °C) to 130 °F (55 °C)

Options:

1. Visualization/control software for MS Windows®
2. Pulse mode operation
3. Water cooling
4. High speed stub drive motors
5. Defined mismatch tuning
6. CAN-Bus or DeviceNet interface
7. CAN-USB adapter
8. DDE server in visualization/control software
9. LabVIEW virtual instrument
10. 24 VDC power supply (bench top)



GERLING APPLIED
ENGINEERING, INC.

© 2010 Gerling Applied Engineering, Inc.
PO Box 580816 ▪ Modesto, CA 95358 ▪ USA
Phone: +1-209-527-8960 ▪ Fax: +1-209-527-5385
E-mail: sales@2450MHz.com ▪ Web: www.2450MHz.com

Automatic Impedance Matching System, WR340

GERLING

Model GA1022

Ordering Information:

Description

Automatic Impedance Matching System, WR340 (basic model)
GA1022 (basic model) with options 1, 2, 3, 5, 9 and 10

GAE Part Number

GA1022
913502

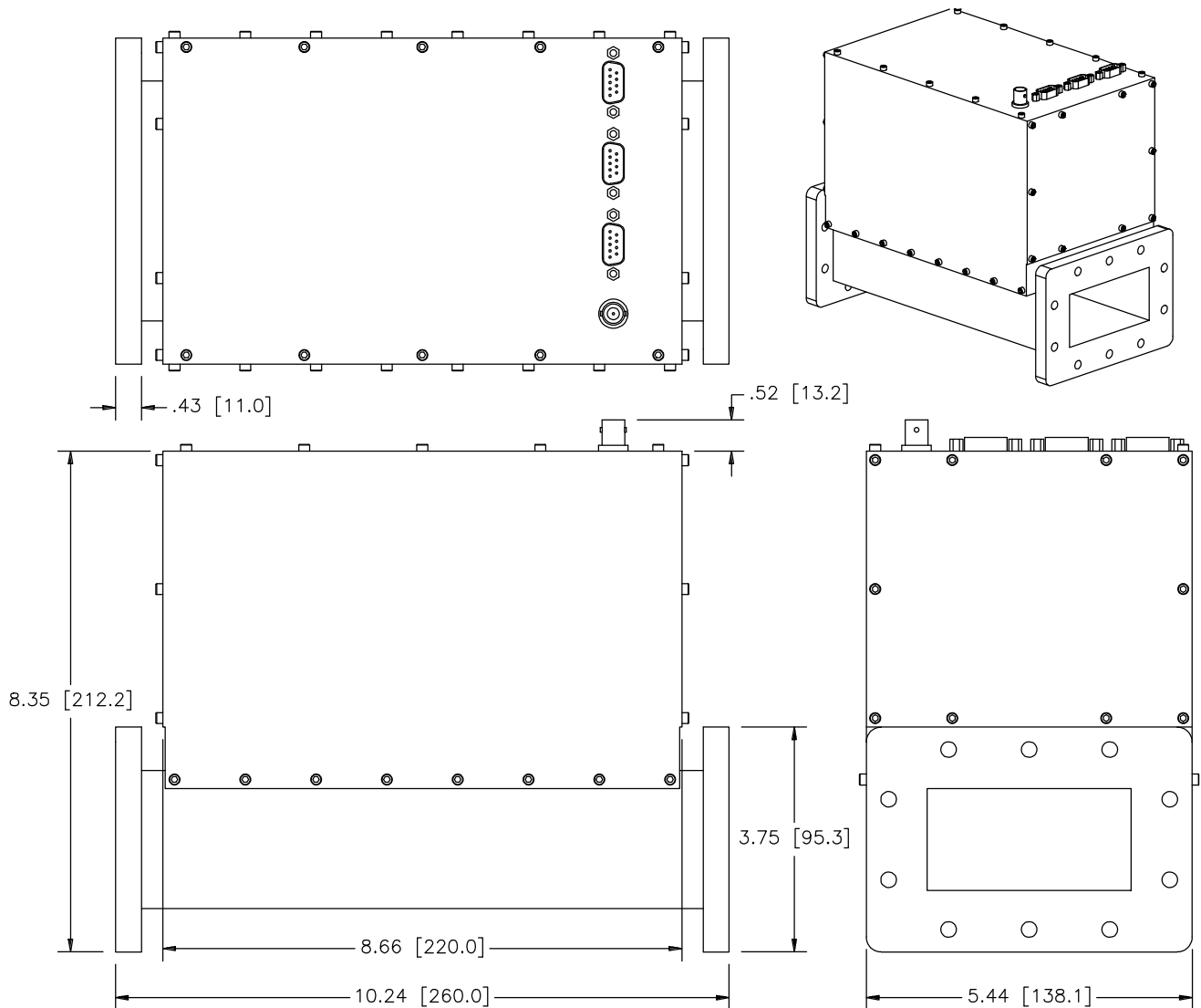

GERLING APPLIED
ENGINEERING, INC.

© 2010 Gerling Applied Engineering, Inc.
PO Box 580816 ▪ Modesto, CA 95358 ▪ USA
Phone: +1-209-527-8960 ▪ Fax: +1-209-527-5385
E-mail: sales@2450MHz.com ▪ Web: www.2450MHz.com

All dimensions are in inches [millimeters].