

# 90° H-Plane Bend, WR340

GERLING

## Model GA2310

### Specifications:

Waveguide:	WR340
Flange:	CPR340F (UG554/U)
Material:	6061-T6 Aluminum
Construction:	Dip braze per MIL-B-7883, Type V, Class B
Finish:	Clear chemical film per MIL-C-5541, Class 1A
VSWR:	1.10 (max.)
Insertion Loss:	.02 dB (max.)
Length A/B Min, Max:	2.75 (70); 48.00 (1219)

### Ordering Information:

Model Number Format: **GA2310** = Standard model with 5" lengths (dimensions "A" and "B")

#### **GA2310-Y.YY-Z.ZZ**

Y.YY = "A" flange dimension (inches)

Z.ZZ = "B" flange dimension (inches)

Optional Threaded Inserts: Add "H" or "M" after dimension suffix where inserts are desired (H = 1/4-20 UNC; M = M6 metric)

Example: **GA2310-3.00-4.50H** designates thru-holes at 3.00" flange and 1/4-20 UNC threaded inserts at 4.50" flange

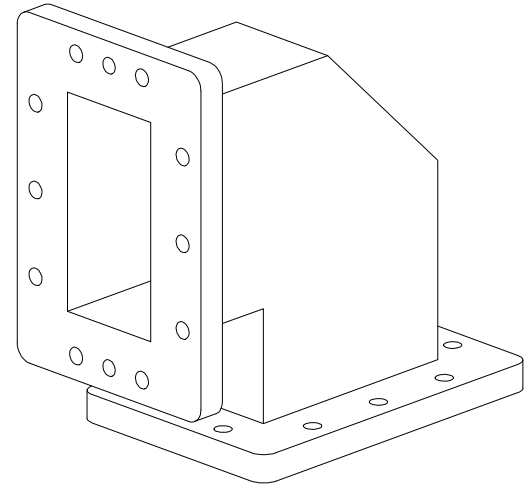

### Options:

- ◆ Threaded studs (SAE or metric)
- ◆ Flange interlock switches
- ◆ Alternate finish (paint)
- ◆ Alternate materials (brass/copper)

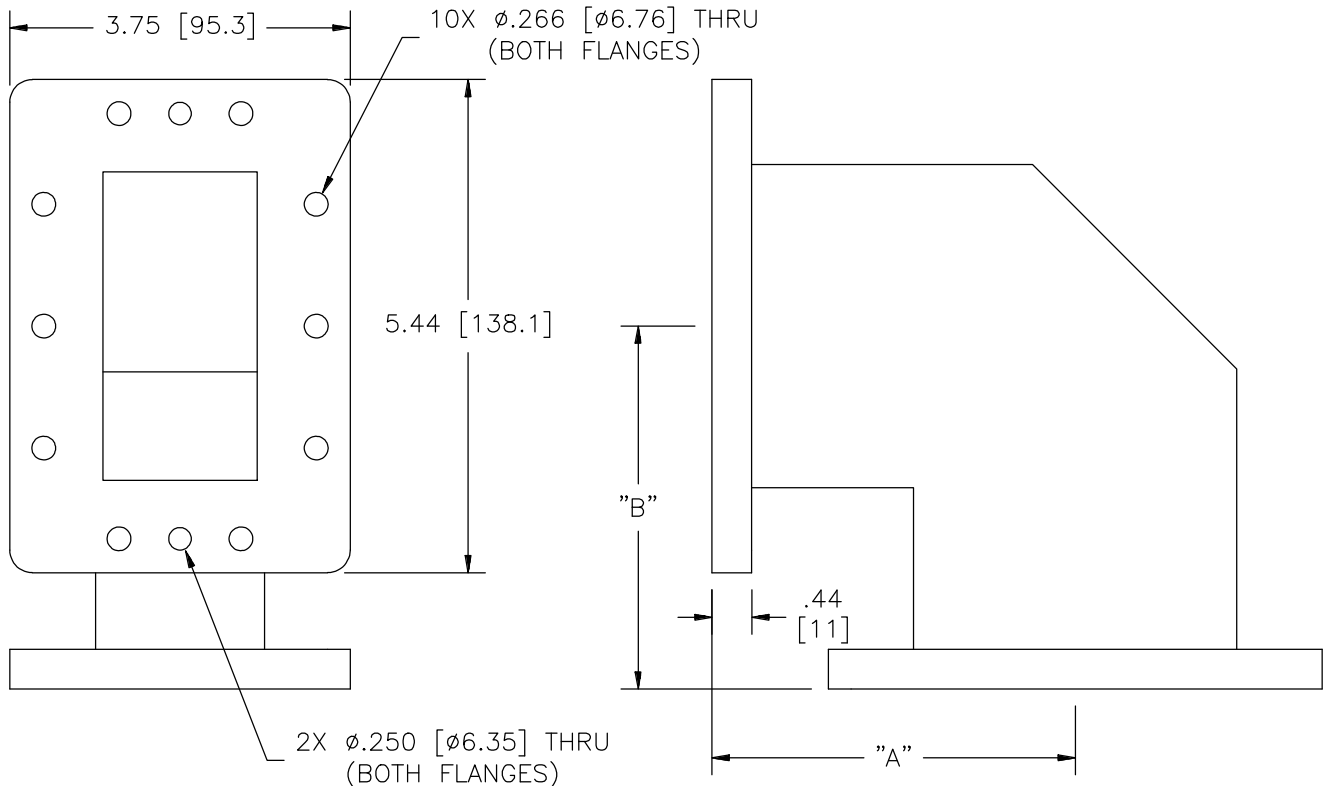

GERLING APPLIED  
ENGINEERING, INC.

© 2003 Gerling Applied Engineering, Inc.  
PO Box 580816 • Modesto, CA 95358 • USA  
Phone: +1-209-527-8960 • Fax: +1-209-527-5385  
E-mail: sales@2450MHz.com • Web: www.2450MHz.com