

45° E-Plane Bend, WR340

GERLING

Model GA2316

Specifications:

Waveguide:	WR340
Flange:	CPR340F (UG554/U)
Bend Type:	Double miter, 1/4-guide wavelength
Material:	6061-T6 Aluminum
Construction:	Dip braze per MIL-B-7883, Type V, Class B
Finish:	Clear chemical film per MIL-DTL-5541F, Type II, Class 3
VSWR:	1.10 (max.)
Insertion Loss:	.02 dB (max.)
Length A/B Min, Max:	1.75 (44); 48.00 (1219)

Ordering Information:

Model Number Format:	GA2316 = Standard model with 3" lengths (dimensions "A" and "B") GA2316-Y.YY-Z.ZZ Y.YY = "A" flange dimension (inches) Z.ZZ = "B" flange dimension (inches)
Optional Threaded Inserts:	Add "H" or "M" after dimension suffix where inserts are desired (H = 1/4-20 UNC; M = M6 metric)
Example:	GA2316-3.00-4.50H designates thru-holes at 3.00" flange and 1/4-20 UNC threaded inserts at 4.50" flange

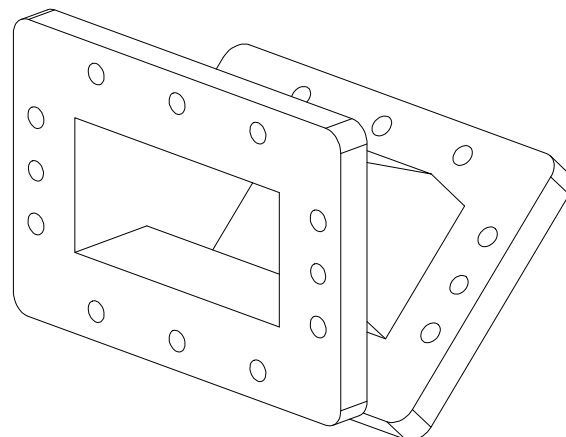

Options:

- ◆ Threaded studs (SAE or metric)
- ◆ Flange interlock switches
- ◆ Alternate finish (paint)
- ◆ Alternate materials (brass/copper)

Accessories:

- ◆ Flange hardware kit, model GA8409 (please specify type and length)
- ◆ Flange bolt interlock, model GA8408

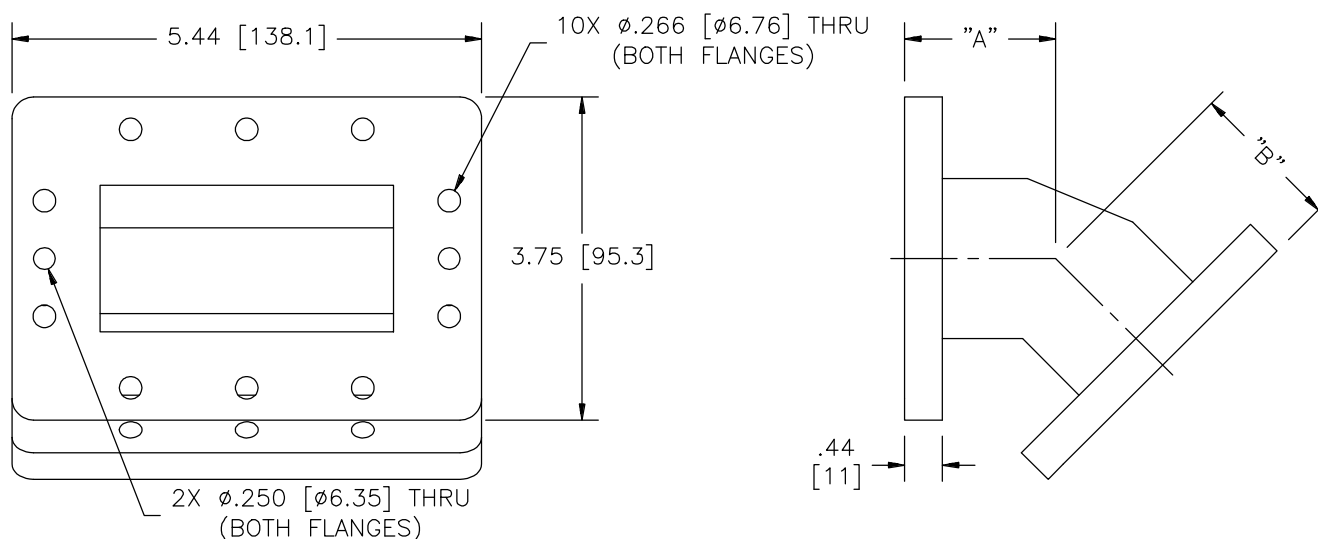

GERLING APPLIED
ENGINEERING, INC.

© 2010 Gerling Applied Engineering, Inc.
PO Box 580816 • Modesto, CA 95358 • USA
Phone: +1-209-527-8960 • Fax: +1-209-527-5385
E-mail: sales@2450MHz.com • Web: www.2450MHz.com