

Pressure/Vacuum Window, WR340

GERLING

Model GA2605

GAE offers a series of waveguide pressure/vacuum windows that deliver good performance at relatively high microwave power levels. The standard models in the series utilize a fused quartz silica window captured between silicone o-rings in an aluminum base. Matching irises located on both sides ensure low VSWR across the ISM band. An additional o-ring is provided for external pressure/vacuum sealing to the mating flange surface. Optional materials are available for higher temperature operation, as well as alternate designs for liquid-cooling.

General Specifications:

Frequency	2450 MHz +/- 50 MHz
Input Power	3 kW continuous max. (into flat load)
Waveguide	WR340 (RG112/U)
Waveguide Flange	UG554/U
Input VSWR	1.2 max.
Insertion Loss	.15 dB max
Operating Temp	-65 to +450 °F (-54 to +232 °C)
Materials	Aluminum base; Fused quartz window; Silicone o-rings
Finish	Chemical conversion coating

Options:

- ◆ Perfluoroelastomer o-rings (recommended for high power, high "Q" applications)
- ◆ Alumina or sapphire window
- ◆ Brass base
- ◆ Clearance holes

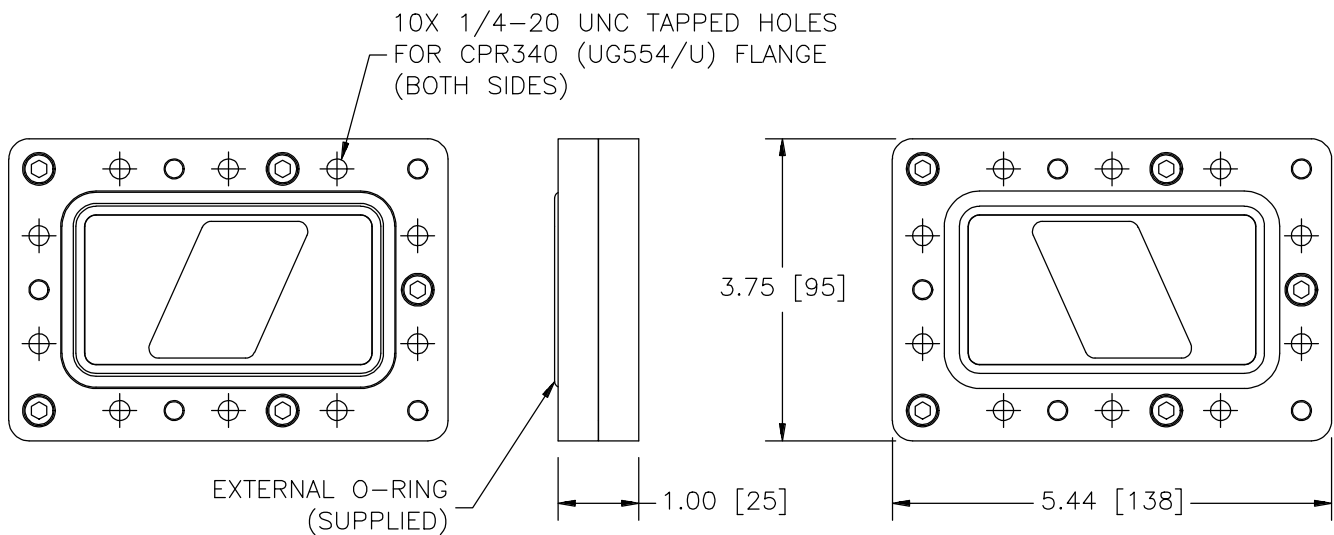
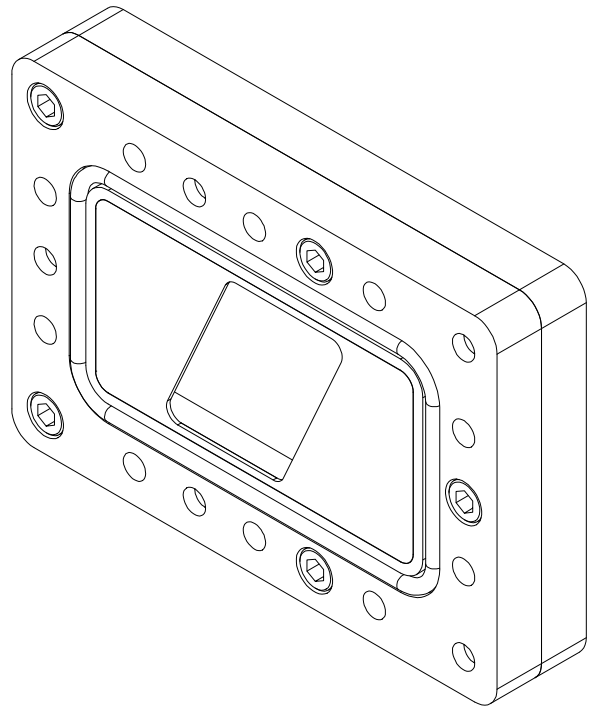

GERLING APPLIED
ENGINEERING, INC.

© 2003-2004 Gerling Applied Engineering, Inc.
PO Box 580816 • Modesto, CA 95358 • USA
Phone: +1-209-527-8960 • Fax: +1-209-527-5385
E-mail: sales@2450MHz.com • Web: www.2450MHz.com