

Universal Waveguide Applicator, WR340

GERLING

Model GA6004A

GAE has designed the Universal Waveguide Applicator (UWA) as a cost-effective means to fulfill the needs of a wide variety of laboratory heating requirements. The standardized waveguide chamber of the UWA can be used with standard or custom adapters (ordered separately) specially designed for heating specific materials. Typical applications include test tube samples, slabs, rods, fluids and plasmas.

The basic design of the UWA is that of a typical broadwall type waveguide applicator. Microwave energy propagates in the TE₁₀ mode which orients the electric field perpendicular to the adapter ports. The e-field varies symmetrically in a sinusoidal manner from a maximum at the center to zero at the side walls. Thus, heating is relatively uniform with respect to sample height but can vary for large widths.

The UWA can be used with a Dummy Load (model GA1202) for traveling wave heating applications or a Sliding Short Circuit (model GA1206) for resonant chamber heating. Depending on the application, typical configurations might also include directional couplers for power measurement (model GA3106 or GA3108) and tuners for impedance matching (model GA1002).

The model GA6004 has two ports on opposite walls. Blank adapters are provided for each port and can be modified by the customer for specific applications. Standard adapters for various applications are also available. Contact GAE for more information on the UWA and standard adapters or design assistance on custom adapters.

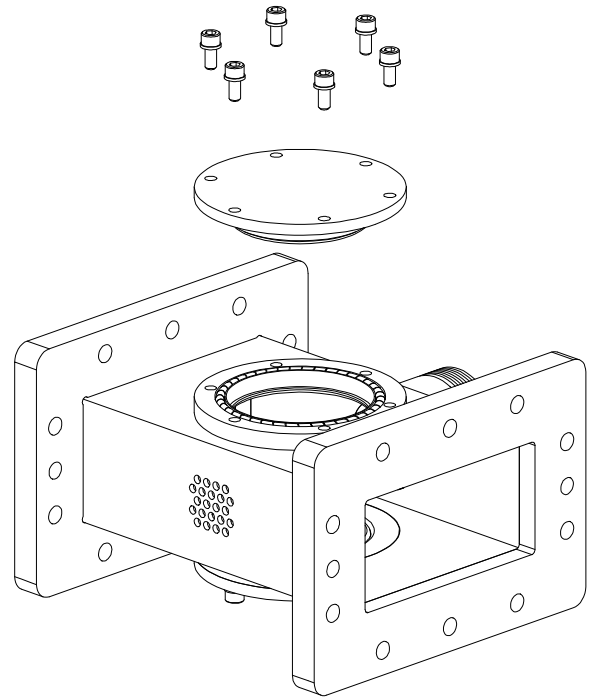

General Specifications:

Waveguide	WR340
Flanges	UG-554/U
Frequency	2450 MHz nominal
Input Power	6 kW continuous max.
Temperature	300°F (150°C) max.
Construction	Aluminum

Options:

- ◆ Heli-Coils or studs on flanges (any combination)
- ◆ Flange interlock switches

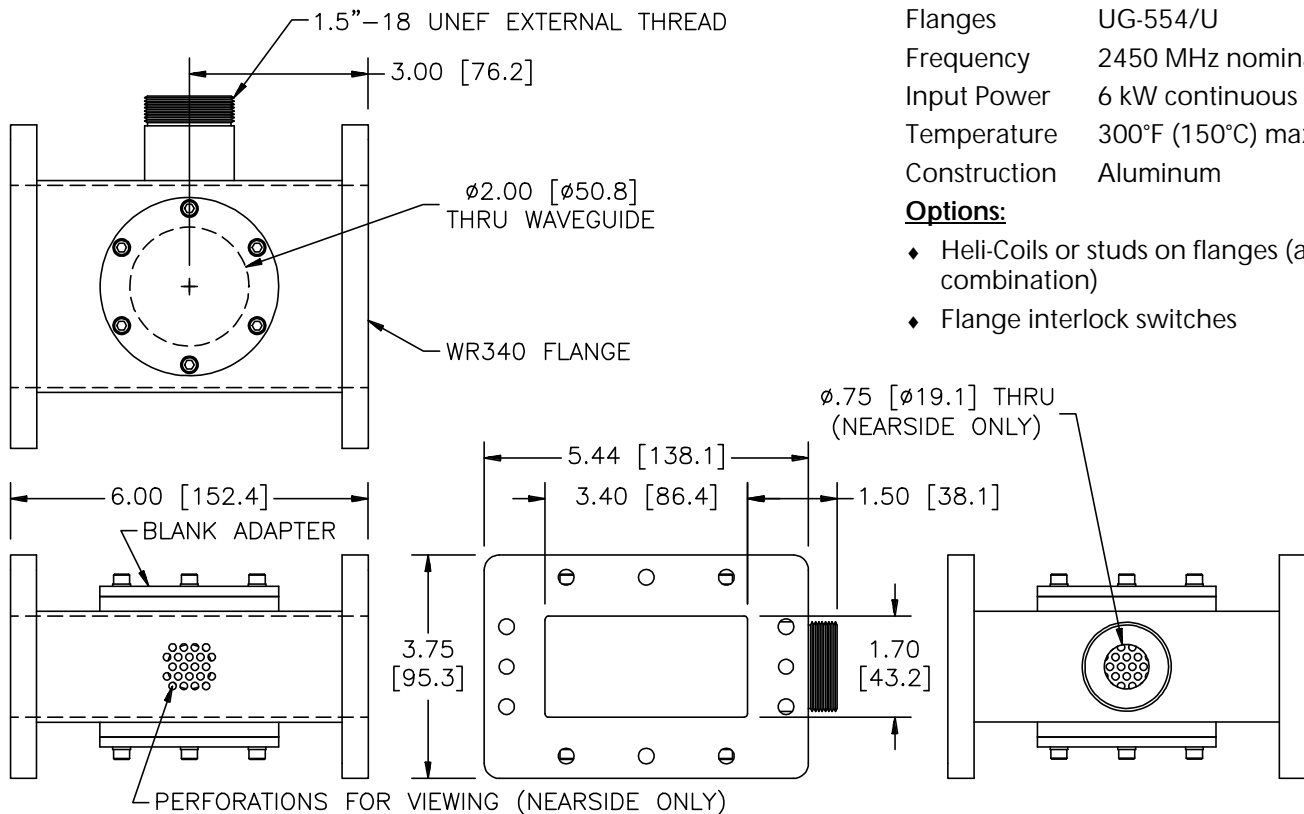

GERLING APPLIED
ENGINEERING, INC.

© 2003-2008 Gerling Applied Engineering, Inc.
PO Box 580816 • Modesto, CA 95358 • USA
Phone: +1-209-527-8960 • Fax: +1-209-527-5385
E-mail: sales@5800MHz.com • Web: www.5800MHz.com